



buzonpedestals.com

PB pedestal (INCH)



PB Range

The PB pedestal is suitable for many different applications and designs. They are adjustable from **15/32"** - **37 5/8"** and are perfect for creating both residential and commercial spaces. Its design makes the PB pedestal easy to adjust and allows quick and sturdy installation. The enlarged surface's head is specially adapted for supporting natural stone, ceramic tiles, concrete pavers, or terraces made of timber or composite decking.



with couplers

■ Fixed

■ Adjustable

COMPOSITION



1 TOP OF THE PEDESTAL

The top of the pedestal is directly screwed into the base, or into the couplers for additional height requirements. The top has a diameter of $6 \frac{11}{16}$ " and a surface area of **35,185** sq. inches. It can various accessories for different applications such as paving, decking or metal grating.

2 COUPLERS

Couplers are used to extend the pedestals height to the required finished floor level up to $37 \frac{5}{8}$ ".

3 BASE

The base can be simply positioned or fixed to any compatible substrate. The head, the couplers and the base are equipped with a safety interlocking system. The base is composed of 8 holes ensuring complete drainage. Base diameter $7 \frac{3}{4}$ ", surface area **47.27** sq. inches.

4 SLOPE CORRECTOR (0 TO 5%)

The U-PH5 slope corrector is placed under the base of the pedestal guaranteeing that the pedestal remains vertical and well balanced even at the highest range. It can compensate for slopes between **0 to 5%** into.



with couplers

Pedestals with the possibility to use U-PH5 slope corrector on the base (PB-0-S12 > PB-11)

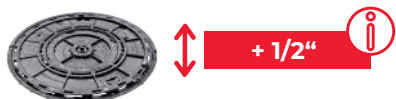

With the U-PH5 slope corrector, the additional height is $\frac{1}{2}$ ".



PB-C1 & PB-C2

PB couplers are fitted by screwing between the base and pedestal's head to make the taller pedestals in the PB range. With the addition of the single and double coupler pedestals can reach a height up to **37 $\frac{5}{8}$ "**.

Couplers are used from **PB 5** to **PB 11**



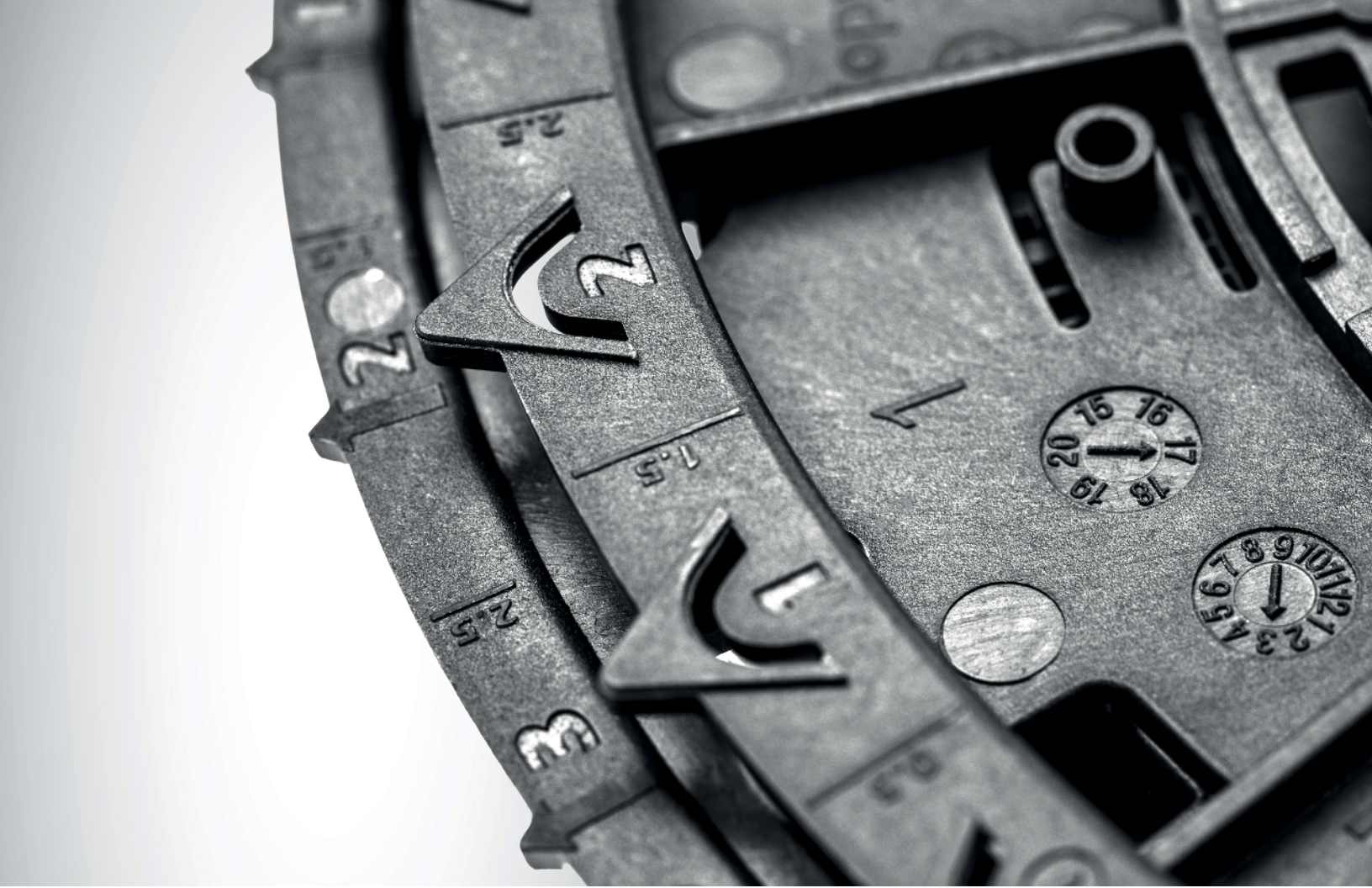

Slope corrector U-PH5

The U-PH5 slope corrector is an adjustable unit which is placed under the base of the PB pedestal. It creates slopes of **0-5%** in **0.5%** intervals meaning a horizontal or inclined terrace can be easily installed.

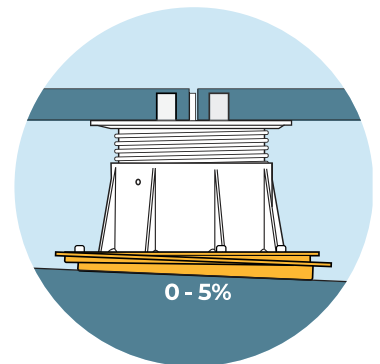



Spacer tabs

Spacer tabs are available in various thicknesses : $3/32''$, $1/8''$, $3/16''$, $1/4''$, and provide uniform alignment of the pavers, placed on top of the Buzon® pedestal. All tabs are $22/32''$ high.

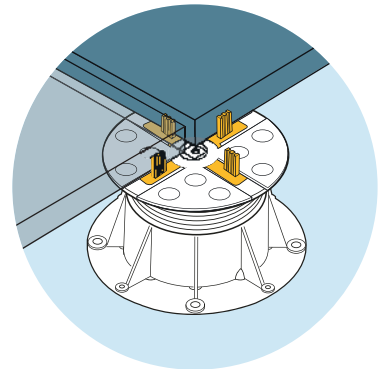

PB-TABS

$3/32''$ 2mm



PB-TABS

$1/8''$ 3mm



PB-TABS

$3/16''$ 4,5mm



PB-TABS

$1/4''$ 6mm

Shock absorber/Shims

The shim (U-E10 or U-E20) is a $1/16''$ or $3/32''$ or maltase-cross shaped leveller. It stabilises the paver, provides additional acoustic comfort, and compensates for variations in paver thickness.

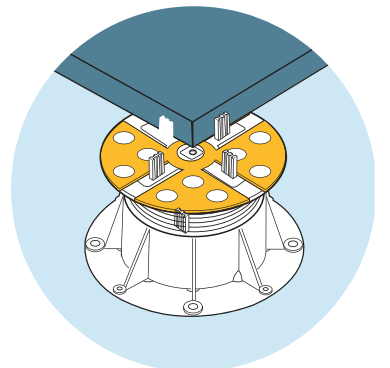

U-E10

$1/16''$ 1mm



U-E20

$3/32''$ 2mm

PB-KIT-5

The PB-KIT-5 support for joists is fixed in using our plug-in system onto the head of the Buzon® PB pedestal. They firmly hold the joist supporting the deck boards in place.

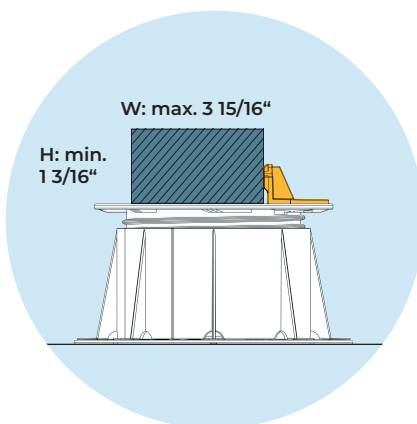

PB-KIT-5

PB-END Finishing Kit

The PB-END finishing kit supports the perimeter tiles to conceal the space created beneath the deck installed on pedestals from the PB range. Two brackets situated on the head and base of the pedestal hold the vertical 13/16" thick tile cuts in place to give a solid and seamless finish.

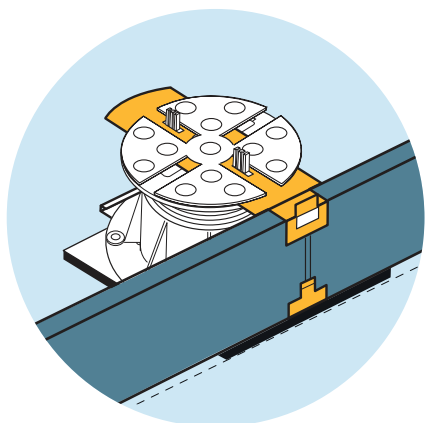

PB-END

LATERAL SIDE

U-BRS Alu Joist system



U-BRS

Spacer tabs

- 3/32" 2mm
- 1/8" 3mm
- 3/16" 4,5mm



RECOMMENDED POSITIONS OF THE PEDESTALS UNDER THE PAVERS

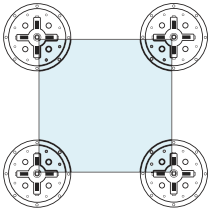

16" X 16" 400 x 400 mm
20" X 20" 500 x 500 mm
24" X 24" 600 x 600 mm

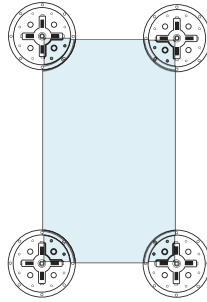

16" X 24" 400 x 600 mm

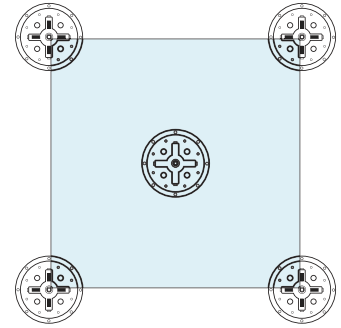

30" X 30" 750 x 750 mm

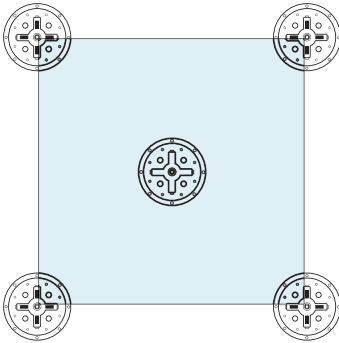

32" X 32" 800 x 800 mm

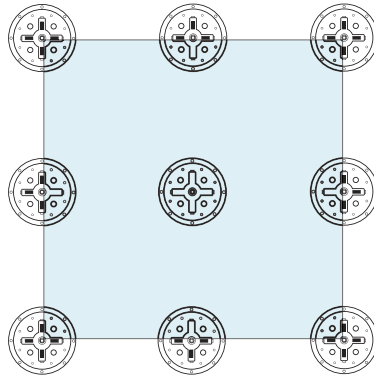

36" X 36" 900 x 900 mm

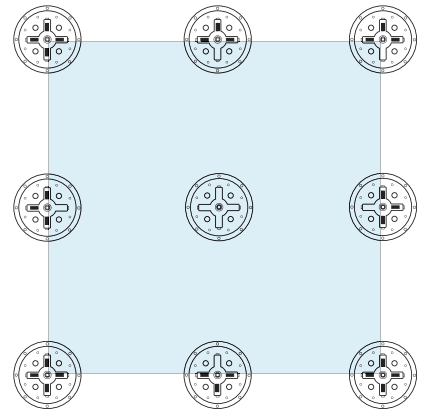

40" X 40" 1000 x 1000 mm
48" X 48" 1200 x 1200 mm

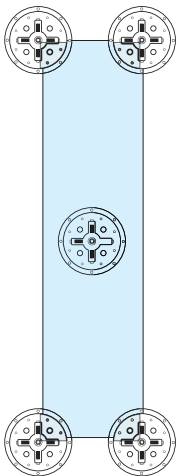

8" X 48" 200 x 1200 mm

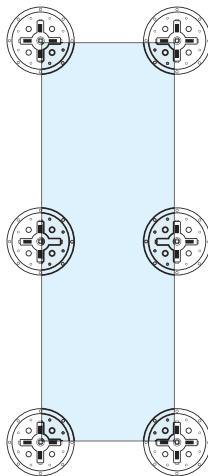

12" X 48" 300 x 1200 mm
16" X 48" 400 x 1200 mm

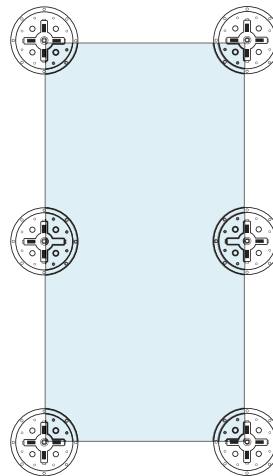

24" X 48" 600 x 1200 mm

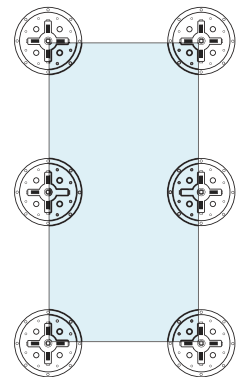

18" X 36" 450 x 900 mm



- **ALLOWS FOR COMPLETE DRAINAGE**
- **QUICK AND EASY INSTALLATION**
- **HIGH STABILITY THANKS TO A LARGE PEDESTAL HEAD**
- **EASY AND PRECISE SLOPE CORRECTION UP TO 5%**
- **DOES NOT HARM WATERPROOF MEMBRANE**
- **EASY ACCESS TO WATERPROOFING MEMBRANE**
- **BETTER THERMAL AND SOUND INSULATION**
- **PROVIDES A SUSTAINABLE SOLUTION**
- **SUPPORTS LARGE LOADS**
- **ABILITY TO CONCEAL SERVICES SUCH AS ELECTRICAL, PLUMBING ETC.**

Advantages of the pedestals



CERAMIC TILES
Apartement Dune-Mielno /
Poland



WOOD DECKING
Jeltikovo Terrace /
Poland



Terrace ceramic
Miami Terrace /
USA

Range of applications



CERAMIC TILES
Torre Glorieta-Mexico City /
Mexico



COMPOSITE DECKING
Béemster Condo /
Netherlands



WASHINGTON - SEATTLE
BAY VISTA

Buzon USA West Projects

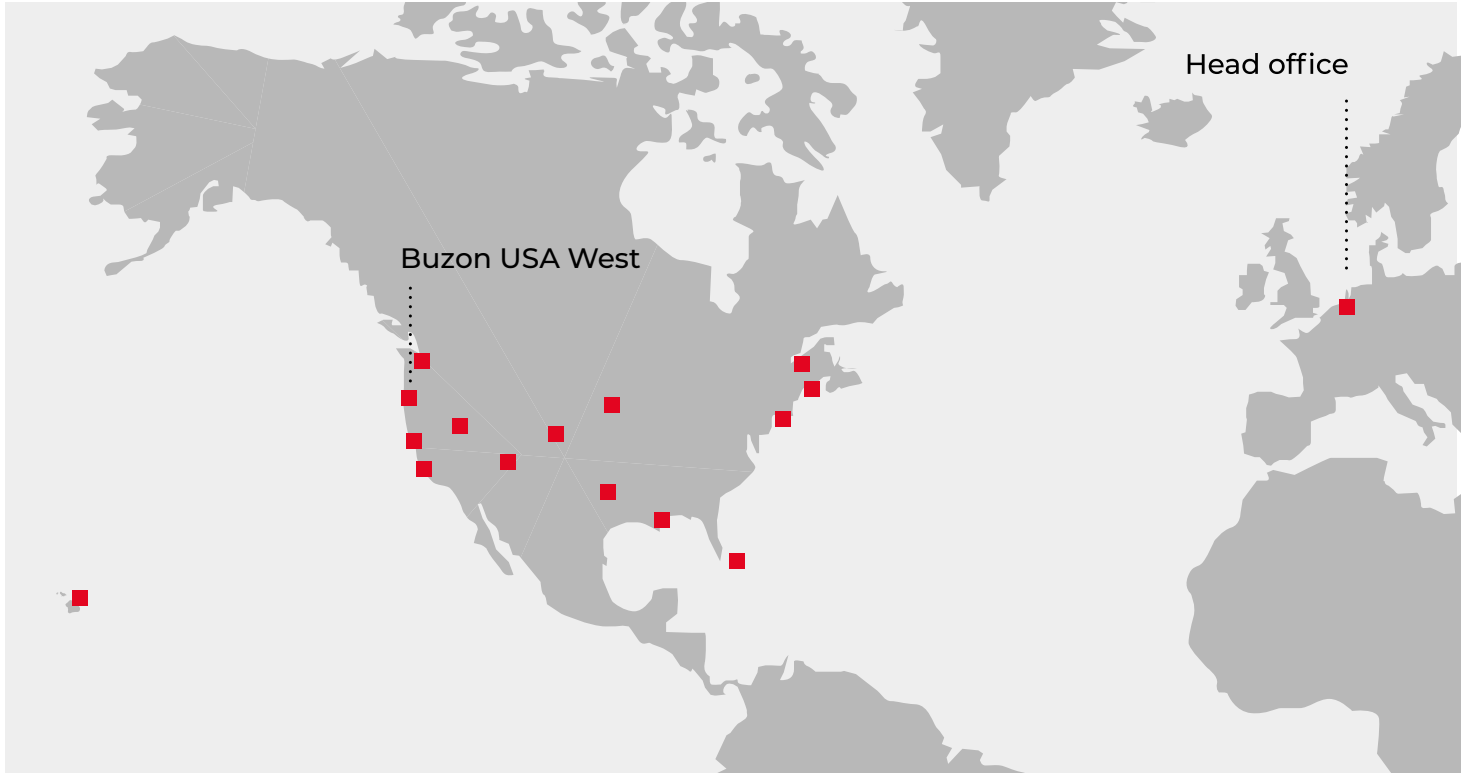

References

- Sun's Practice Facility - Phoenix, AZ
- Sony Studio HQ - Los Angeles, CA
- Apple Campus - Palo Alto, CA
- Samsung HQ - Palo Alto, CA
- Lucille Packard Children's Hospital - Stanford, CA
- Haas School of Business - UC Berkeley, CA
- IMAX Theater - Nassau, Bahamas
- Four Seasons Hotel - Honolulu, HI
- Canal Street Rooftop Pool - New Orleans, LA

- Smith Center Harvard University - Cambridge, MA
- Microsoft Campus - Redmond, WA
- The Dean - Palo Alto, CA
- Nike Campus HQ - Beaverton, OR
- Hoakalei CC - Ewa Beach, HI
- Hilton Grand Islander - Honolulu, HI
- Four Seasons Resort at Ko Olina - Kapolei, HI
- One World Trade Center - New York City, NY
- Wynn Resort & Casino Hotel - Las Vegas, NV

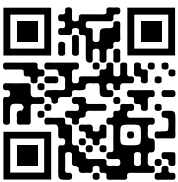

Buzon®
Buzon USA West
sales@buzonusawest.com
buzonpedestals.com
(503) 954 - 3336





Providing Architects and Builders with
Superior Paving, Decking and Pedestal Products.

Commercial | Luxury Residential | Municipal

Extended Team

We can also provide technical consultation and installation training for projects that involve Buzon Pedestals. Please contact us to discuss your particular needs. HDG Building Materials also has a network of experienced installers in many major cities. Please contact us for introductions or referrals.

Sales Representatives

Sales representatives for HDG Building Materials are located in the Pacific Northwest, Southern California, and Iowa.

Outside of those regions? No problem, we are happy to serve. Please contact us at 503.360.9551



HDG Building Materials
Commercial | Luxury Residential | Municipal

4508 SE Ascension Drive
Camas, WA 98607

HDG Building Materials is an expert dealer
for Buzon Pedestals International.
HDG provides architectural
sales and support in North America.

503.360.9551

sales@hdgbuildingmaterials.com